

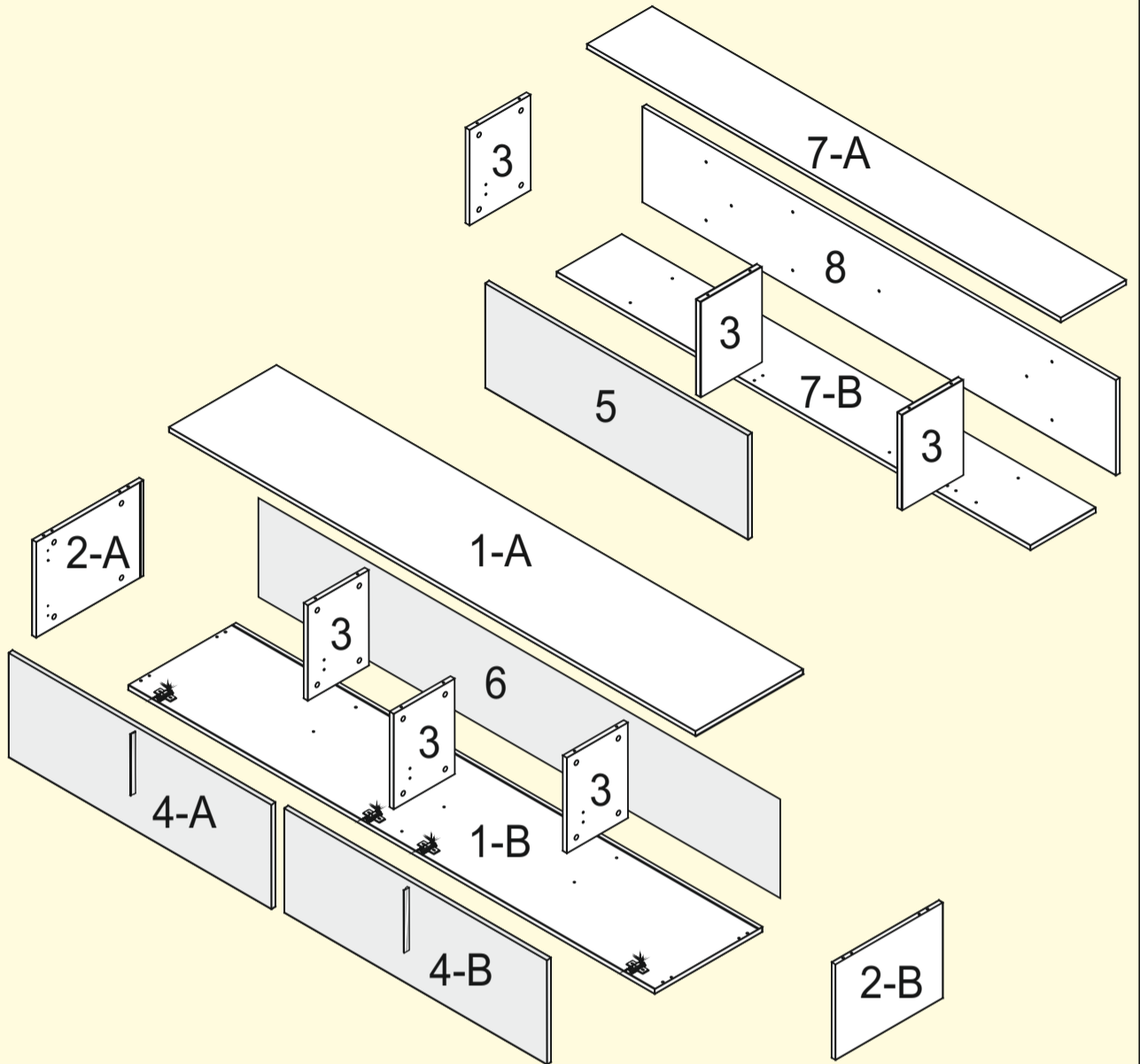

**Forés**  
... con madera de hogar!

**SALON TV**  
TV LIVING ROOM  
MÓVEL PARA SALA  
SÉJOUR TV

**6640**

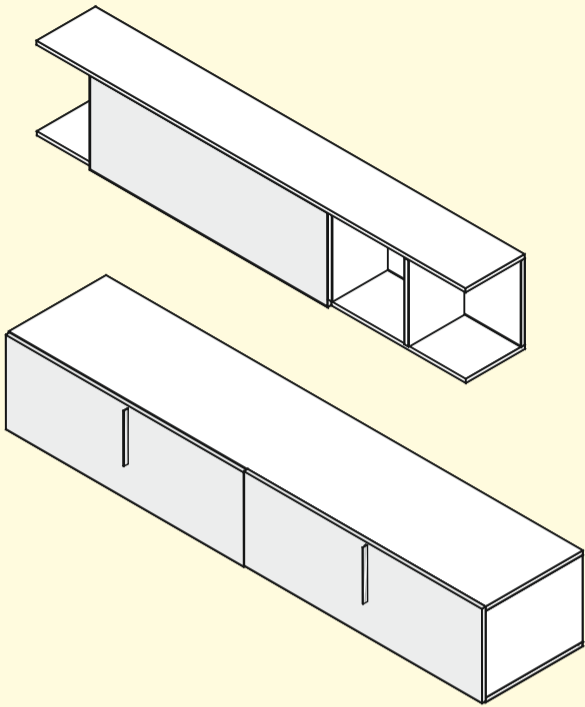

<p><b>RECOMENDACIONES PARA EL MONTAJE</b></p> <ul style="list-style-type: none"> <li>PREPARAR LAS PIEZAS QUE CONSTITUYEN EL MUEBLE.</li> <li>REAGRUPAR Y CONTAR EL HERRAJE.</li> <li>PREPARAR LAS HERRAMIENTAS NECESARIAS.</li> <li>PREPARAR LA ZONA DE MONTAJE.</li> <li>REALIZAR EL MONTAJE SOBRE UNA MOQUETA PARA EVITAR RAYAR EL MUEBLE.</li> <li>NO FORZAR NUNCA LOS ENSAMBLAJES.</li> <li>GUARDAR ESTE FOLLETO. SI UNA PIEZA FALTA COMUNIQUELO A SU ALMACEN.</li> </ul>	<p><b>RECOMENDACIONES PARA EL USO</b></p> <ul style="list-style-type: none"> <li>NO COLOCAR CERCA DE FUENTES DE CALOR.</li> <li>NO ADHERRIR ADHESIVOS O PRECINTOS SOBRE LOS MUEBLES. LOS CAMBIADOS PUEDEN RESULTAR DAÑADOS.</li> <li>NO UTILIZAR PAÑOS O TRAJOS O PRODUCTOS DE LIMPIEZA QUE PUEDAN RAYAR LA SUPERFICIE DEL MUEBLE.</li> <li>MUEBLE APTO PARA USO DOMÉSTICO. UBICACIÓN EN EL INTERIOR DE LA VIVIENDA.</li> </ul>	<p><b>RECOMMENDATIONS FOR FITTING</b></p> <ul style="list-style-type: none"> <li>PREPARE FOR FITTING.</li> <li>PREPARE THE PIECES OF FURNITURE TO MAKE IT UP.</li> <li>GROUP UP AND COUNT THE IRON PARTS, SCREWS... ETC.</li> <li>PREPARE THE NECESSARY TOOLS.</li> <li>PREPARE THE FITTING PLACE.</li> <li>DO THE FITTING ON A CARPET SO YOU DON'T DAMAGE THE FURNITURE.</li> <li>NEVER FORCE THE FITTING.</li> <li>KEEP THIS LEAFLET. IF THERE IS A PIECE MISSING GET IN TOUCH WITH YOUR SUPPLIER.</li> </ul>	<p><b>RECOMMENDATIONS FOR USE</b></p> <ul style="list-style-type: none"> <li>DO NOT PUT NEAR TO ANY SORT OF HEAT.</li> <li>DO NOT STICK ANYTHING ON THE FURNITURE. YOU COULD DAMAGE IT.</li> <li>DO NOT USE CLOTHS OR CLEANING PRODUCTS THAT COULD DAMAGE THE SURFACE OF THE FURNITURE.</li> <li>FURNITURE SUITABLE FOR DOMESTIC USE. KEEP INDOORS.</li> </ul>
<p><b>AVISO PARA MONTAJE</b></p> <ul style="list-style-type: none"> <li>PREPARAR LAS PIEZAS QUE COMPONEN O MÓVEL.</li> <li>REAGRUPAR E CONTAR AS FERRAGENS.</li> <li>PREPARAR AS FERRAMENTAS NECESSARIAS.</li> <li>PREPARA O LOCAL PARA A MONTAGEM.</li> <li>EFECTUAR A MONTAGEM SOBRE UMA ALFATIFA PARA EVITAR ARRANHAR O MÓVEL.</li> <li>NAO FORNAR NUNCA A ENSAMBLADURA.</li> <li>GUARDAR ESTE FOLHETO. PARA SE LHE FALTAR ALGUMA PEÇA PODER COMUNICA-LO AO ARMAZEM.</li> </ul>	<p><b>AVISO PARA USO</b></p> <ul style="list-style-type: none"> <li>NAO COLOCAR PERTO DE FONTES DE CALOR.</li> <li>NAO PEGAR ADHESIVOS OU PRECINTOS NOS MÓVEIS OS ACABAMENTOS PODEM RESULTAR DANIFICADOS.</li> <li>NAO UTILIZAR PANOS, TRAJOS OU PRODUTOS DE LIMPIEZA QUE POSSAM RISCAR A SUPERFICIE DO MÓVEL.</li> <li>MÓVEL APTO PARA O USO DOMÉSTICO. COLOCAÇÃO NO INTERIOR DA VIVENDA.</li> </ul>	<p><b>CONSEILS DE MONTAGE</b></p> <ul style="list-style-type: none"> <li>AMENAGEZ-VOUS UNE ZONE DE MONTAGE. LA MOQUETTE OU UNE COUVERTURE PROTEGERA DES RAYURES.</li> <li>MUNISSEZ-VOUS DE L'OUTILLAGE NECESSAIRE.</li> <li>REGROUPER ET COMPTER LA QUINCAILLERIE.</li> <li>IDENTIFIER LES DIFFERENTS PANNEAUX.</li> <li>SI MALGRÉ TOUTE NOTRE ATTENTION, DES PROBLÈMES APPARAISSENT, NOUS VOUS CONSEILLONS D'UTILISER CETTE NOTICE POUR COMMUNIQUER AVEC NOTRE SAV.</li> </ul>	<p><b>CONSEILS POUR L'USAGE</b></p> <ul style="list-style-type: none"> <li>NE PAS PLACER PRÈS DES SOURCES DE CHALEUR.</li> <li>NE PAS METTRE DES PRODUITS OU DES RUBANS ADHÉSIFS SUR LES MUEBLES. IES PRODUITS FINIS PEUVENT ÊTRE ADHÈRES.</li> <li>N'UTILISER PAS DE CHIFFONS OU DES PRODUITS DE NETTOYAGE QUI PEUSENT RAYER LA SUPERFICIE DU MUEBLE.</li> <li>MUEBLE APTÉ POUR L'USAGE DOMESTIQUE. ON PEUT LE PLACER AL INTERIEUR DE LA MAISON.</li> </ul>

Reagrupar y contar el herraje. Reagrupar e contar as ferragens.  
Group up and count the iron pieces. Regrouper et compter la quincaillerie.

<b>A x 8</b> 6 x 30mm	<b>B x 1</b> Nº 3		<b>D x 4</b> M4 x 18 mm
<b>C x 2</b> 200 mm	<b>E x 32</b> 15 mm		<b>R x 12</b> 3.5 x 20 mm
<b>F x 32</b>	<b>G x 5</b>		<b>S x 24</b> 4 x 16 mm
<b>H x 3</b> 3 mm	<b>K x 6</b> W		<b>T x 2</b> 3.5 x 16 mm
<b>L x 1</b>	<b>N x 12</b>		<b>U x 12</b> 3 x 13 mm
<b>Ñ x 24</b> 13 mm	<b>O x 3</b> 8 mm		<b>V x 3</b> 5 x 60 mm
<b>P x 32</b> 15 mm	<b>Q x 8</b>		<b>AB x 5</b> 4 x 30 mm
<b>X x 1</b> Nº 4	<b>Y x 2</b>		<b>AC x 6</b> 5 x 50 mm
<b>Z x 1</b>			
<b>J x 6</b>			

**CERRADO MÓDULO BAJO SALÓN**

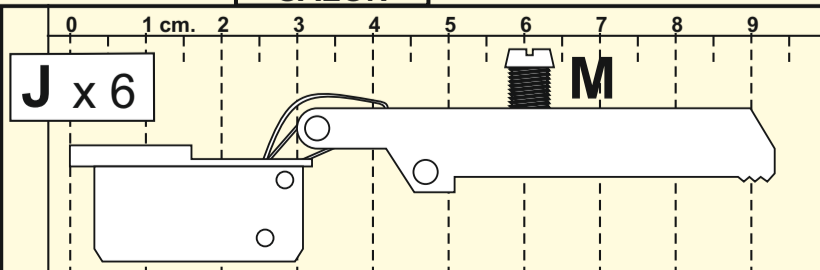

**ABIERTO MÓDULO ALTO SALÓN**

Preparar las herramientas necesarias. Preparar as ferramentas necessárias.  
Prepare the necessary tools. Munissez-vous de l'outillage nécessaire.

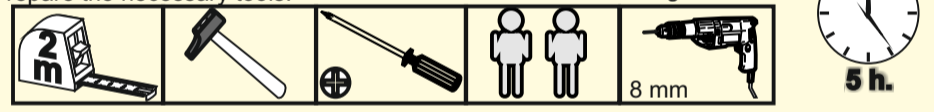

**PIEZAS** Identificar las diferentes piezas. **PIECES** Identify the different pieces. **PIEZAS** Identificar as peças. **PIECES** Identifier les différents panneaux.

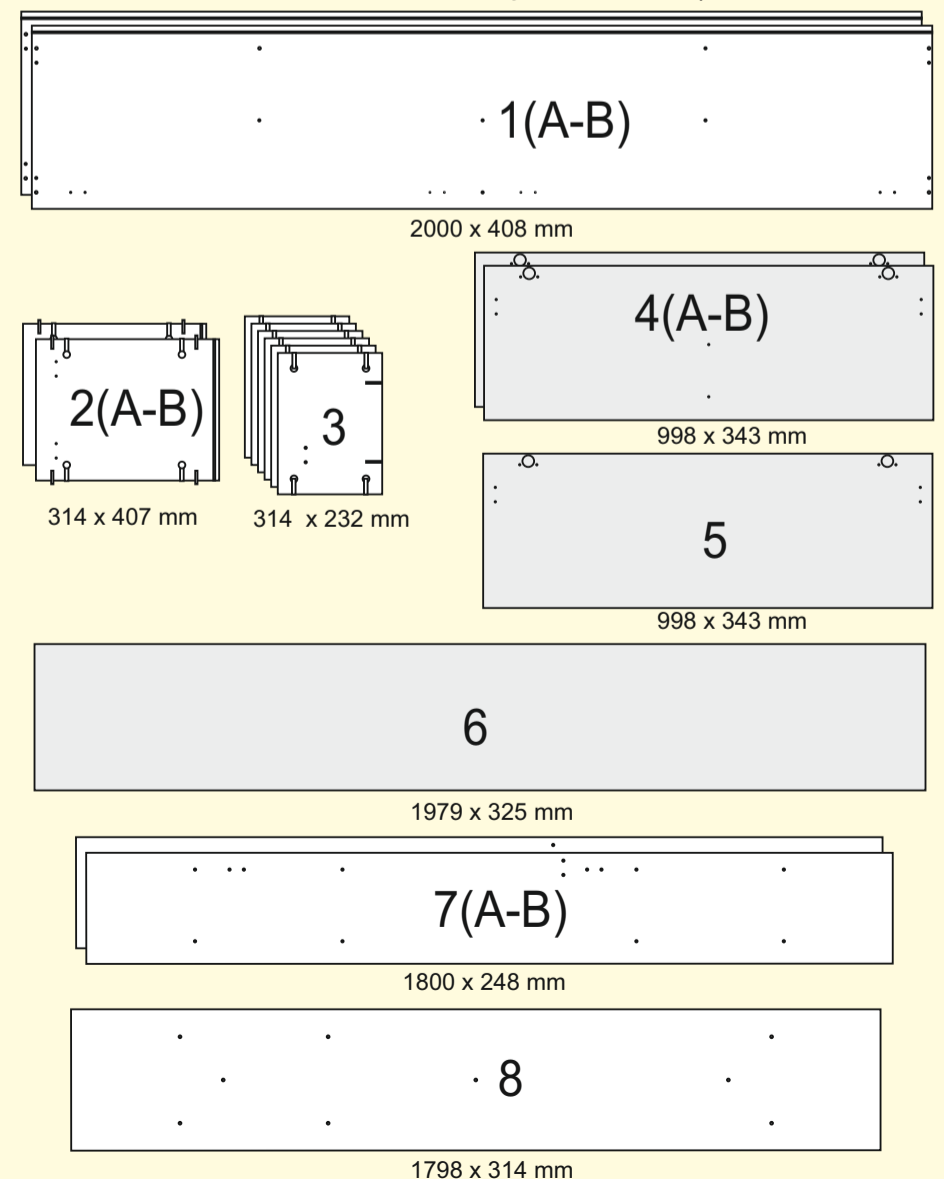

# 1

**F x 10**

**G x 5**

**AB x 5**  
  
4 x 30 mm

**K x 4**

**S x 8**  
  
4 x 16 mm

**1°**

**2°**

**AB**

**G**

50 mm

50 mm

**F**

**S**

**W**

**K**

**F**

**180°**

**DAR LA VUELTA A LA PIEZA**  
**TURN THE OTHER FACE DOWN**  
**VIRAR A PEÇA DO OUTROLADO**  
**DONNER LE TOUR À LA PIÈCE**

# 2

# 3

**F x 10**

**3**

**E x 24**  
  
15 mm

**3(x6)**

**E**

**O**

# 4

# 5

# 6

**Z x 1**

**U x 2**  
  
3 x 13 mm

**3(x1) PISTÓN**

**5**

**A x 4**  
  
6 x 30 mm

**E x 4**  
  
15 mm

**Y x 1**

**U x 2**  
  
3 x 13 mm

**6**

**A x 4**  
  
6 x 30 mm

**E x 4**  
  
15 mm

**Y x 1**

**U x 2**  
  
3 x 13 mm

7

**P x 10**  
  
 15 mm

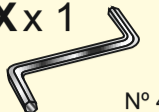
**X x 1**  
  
 N° 4

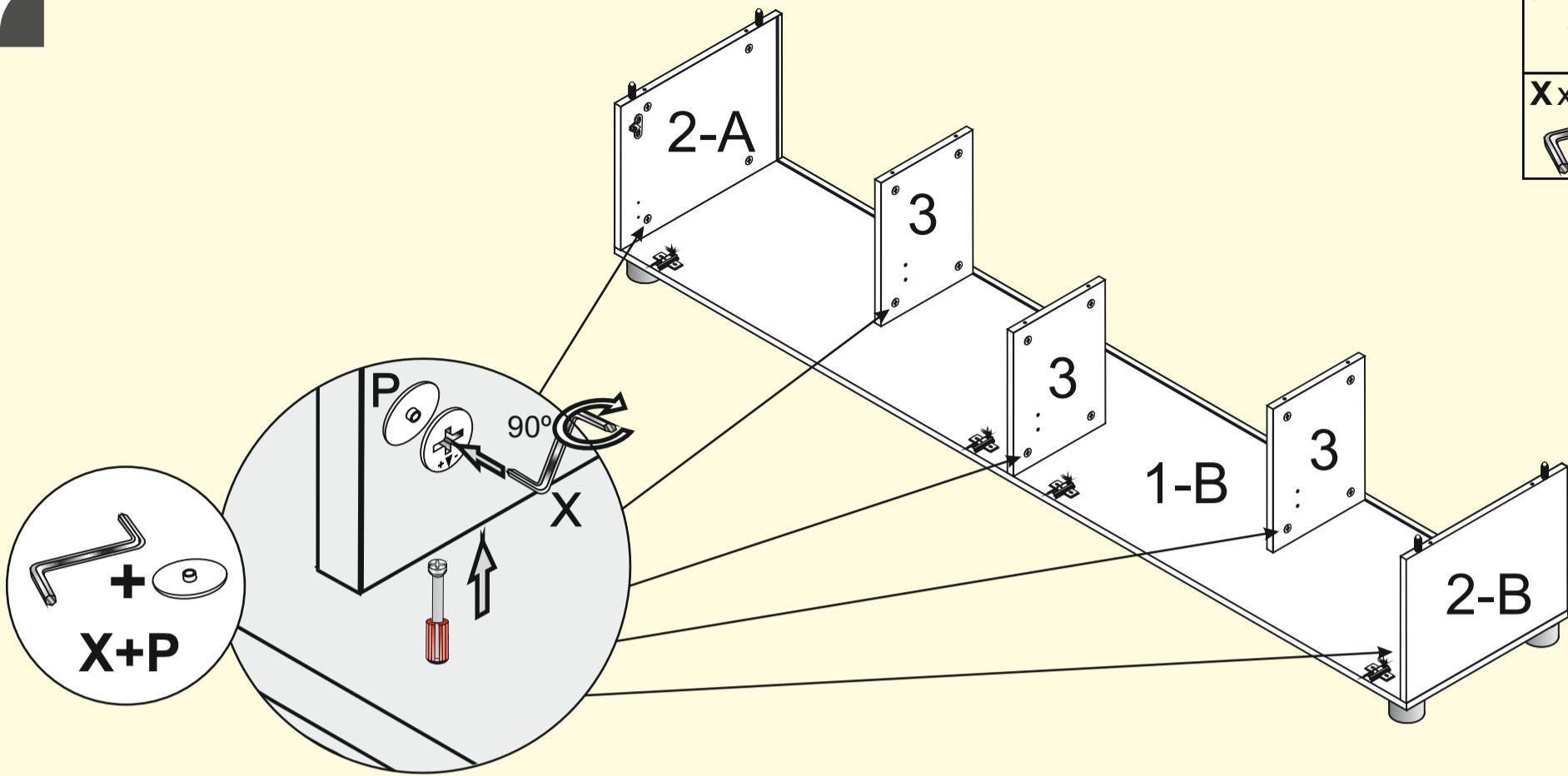

8

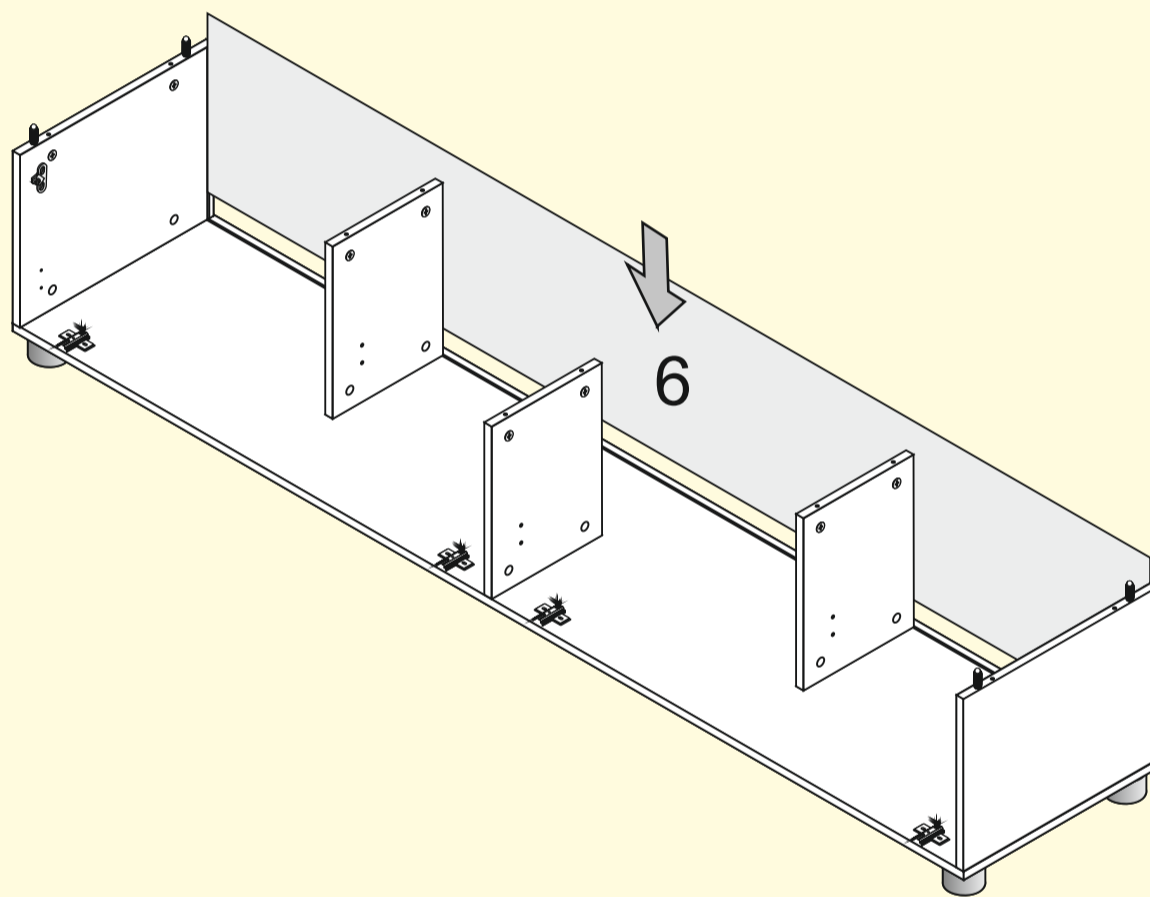

9

**P x 10**  
  
 15 mm

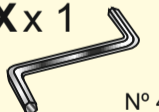
**X x 1**  
  
 N° 4

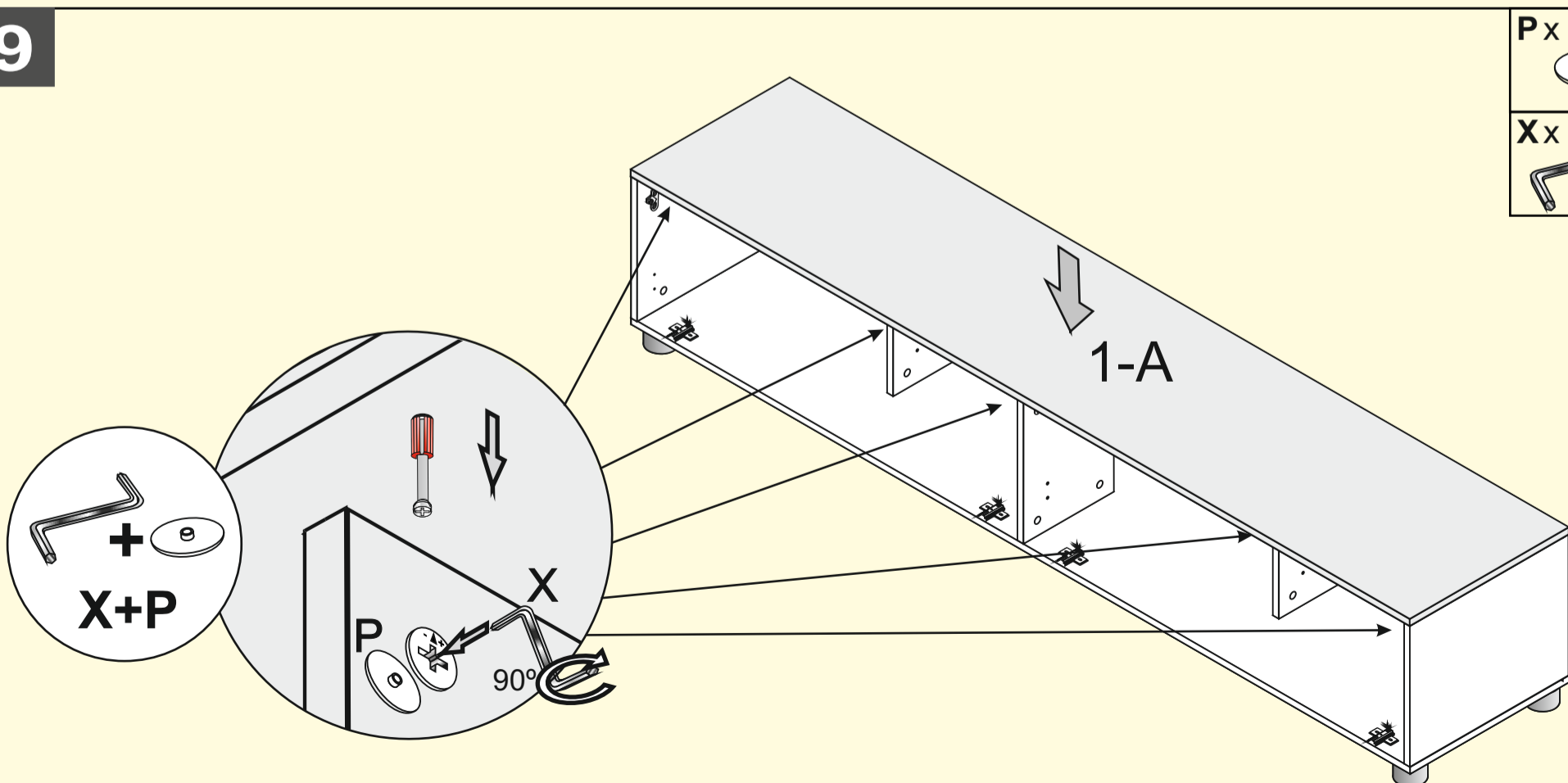

10

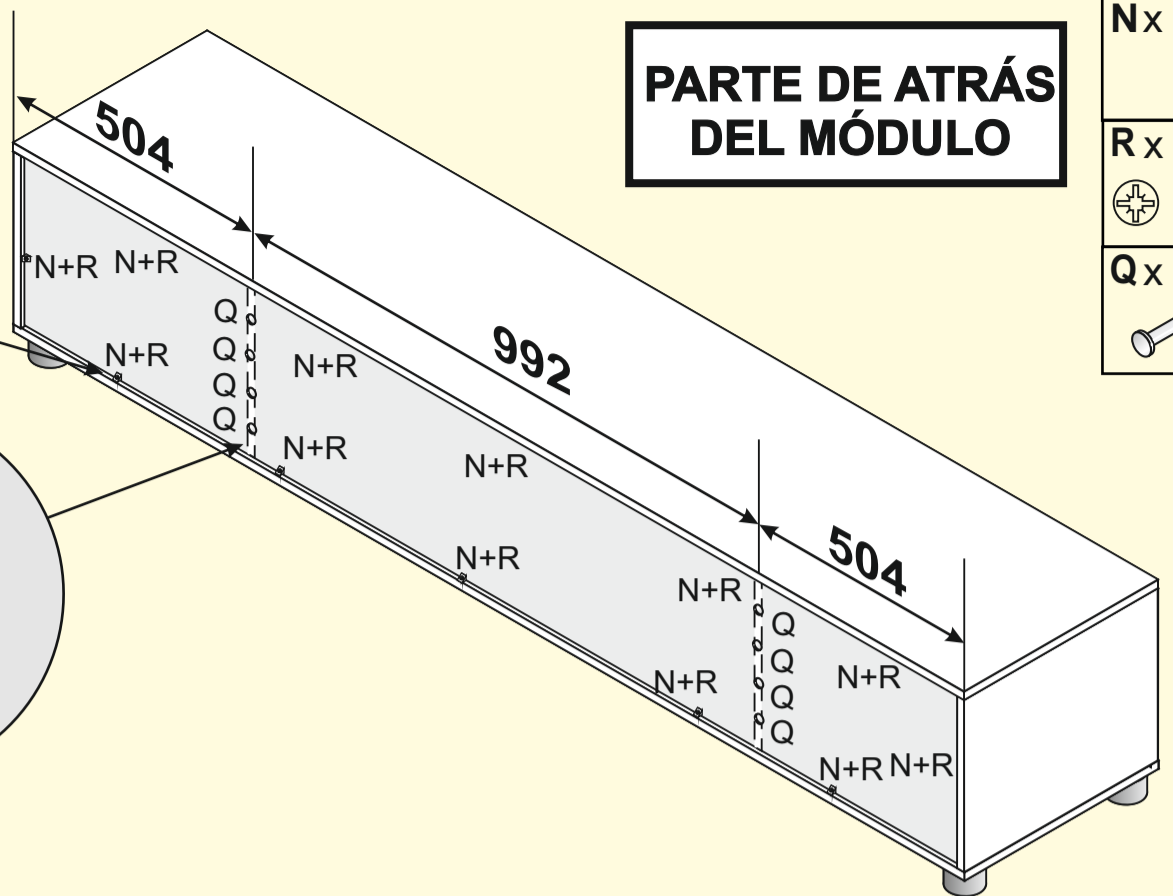
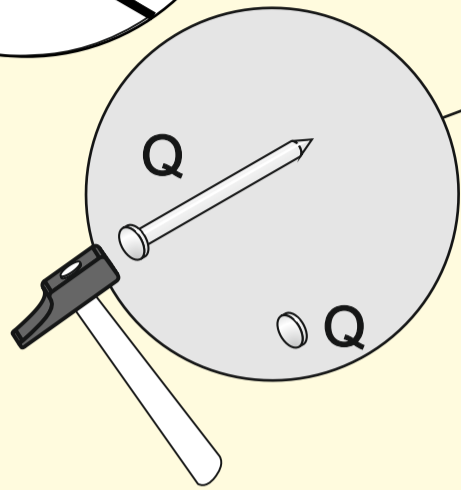
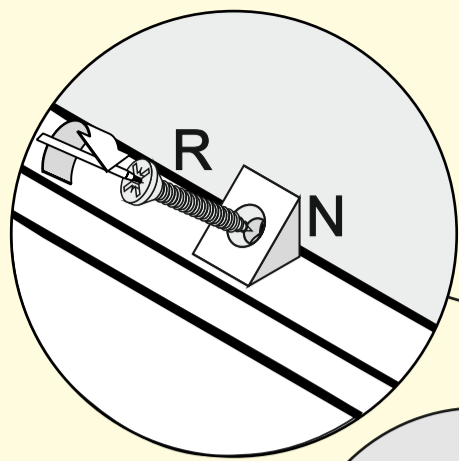



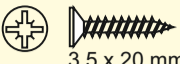
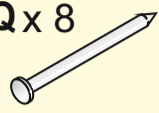

PARTE DE ATRÁS DEL MÓDULO

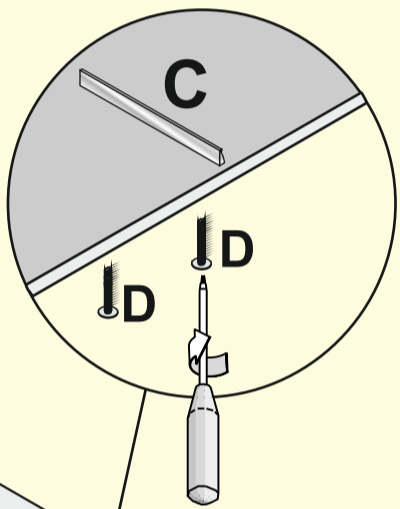
- N x 12 
- R x 12  3.5 x 20 mm
- Q x 8 

11

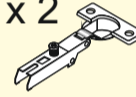

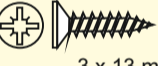

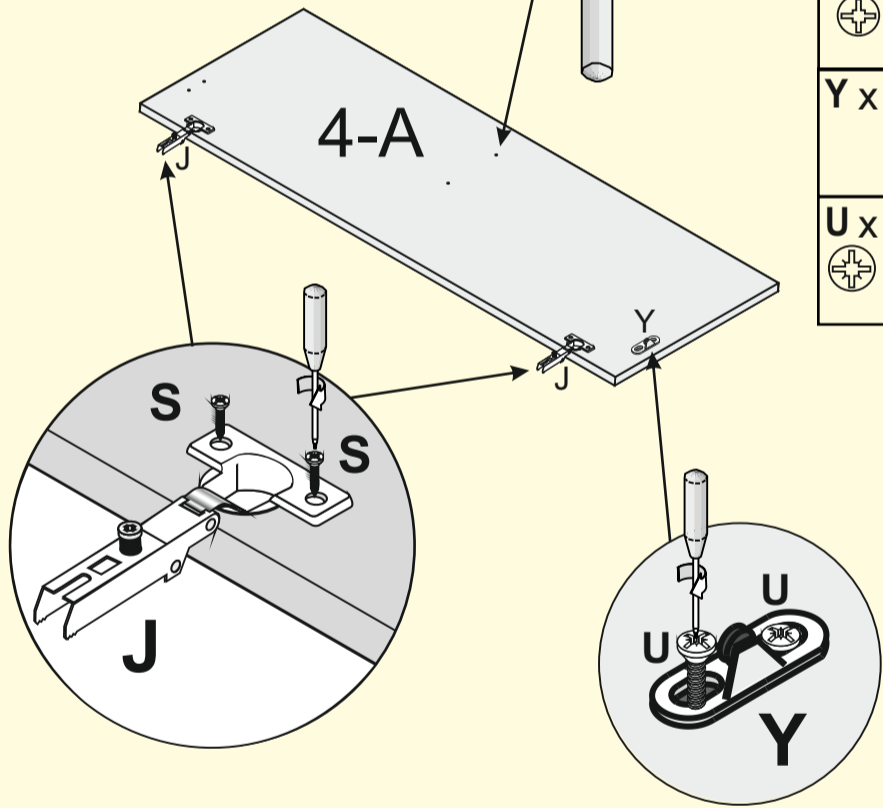
- C x 1  200 mm
- D x 2  M4 x 18 mm
- J x 2 
- S x 4  4 x 16 mm
- Y x 1 
- U x 2  3 x 13 mm

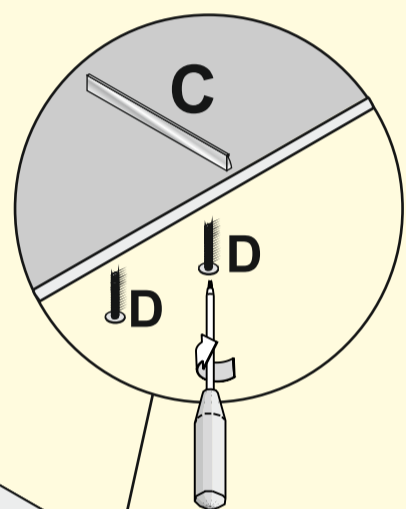

12

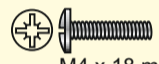
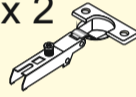

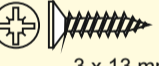

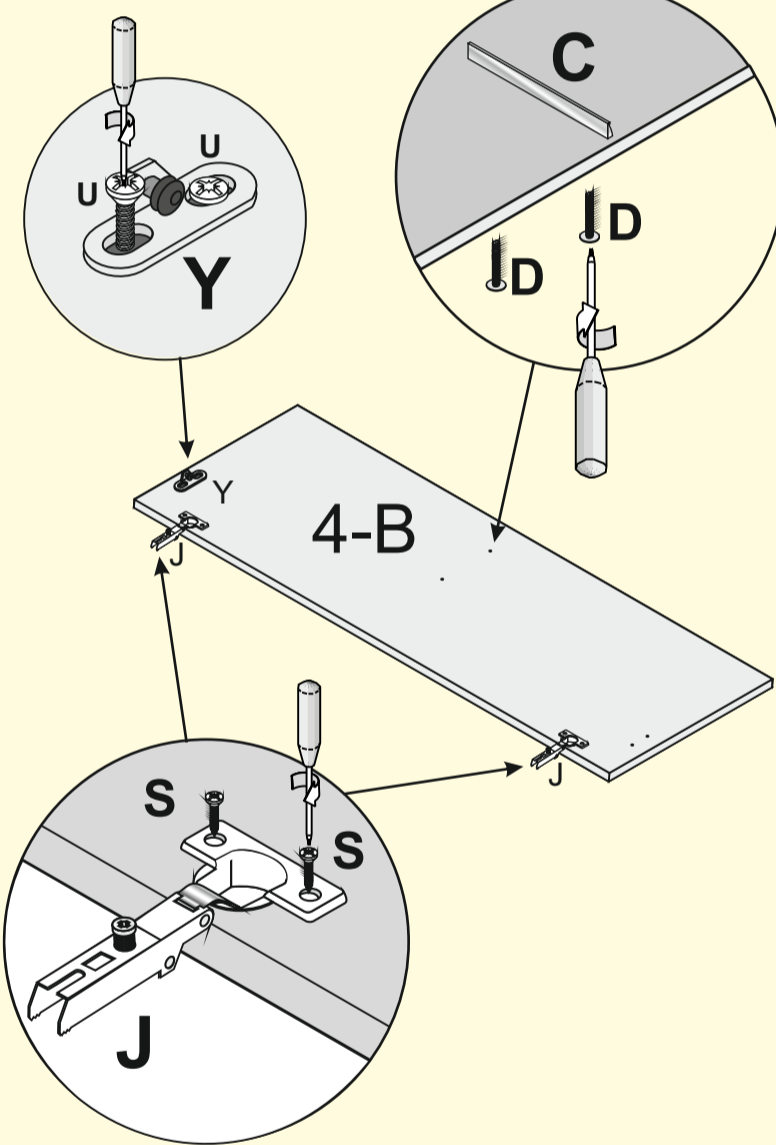
- C x 1  200 mm
- D x 2  M4 x 18 mm
- J x 2 
- S x 4  4 x 16 mm
- Y x 1 
- U x 2  3 x 13 mm

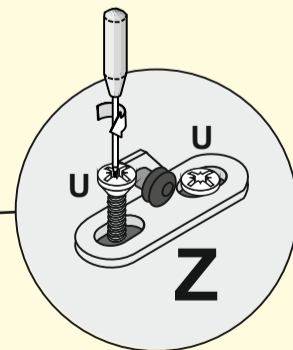
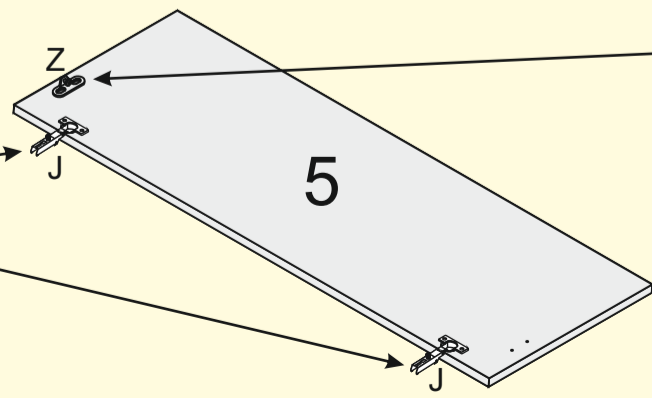
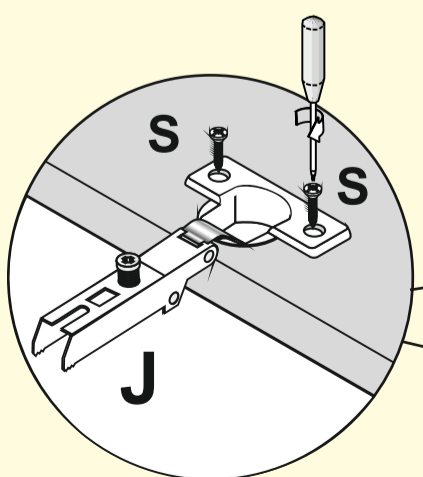

13

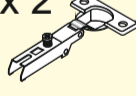

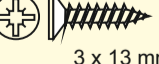
- J x 2 
- S x 4  4 x 16 mm
- Z x 1 
- U x 2  3 x 13 mm

- Ñ x 10  
13 mm
- Y x 2
- CERRADO MÓDULO BAJO SALÓN

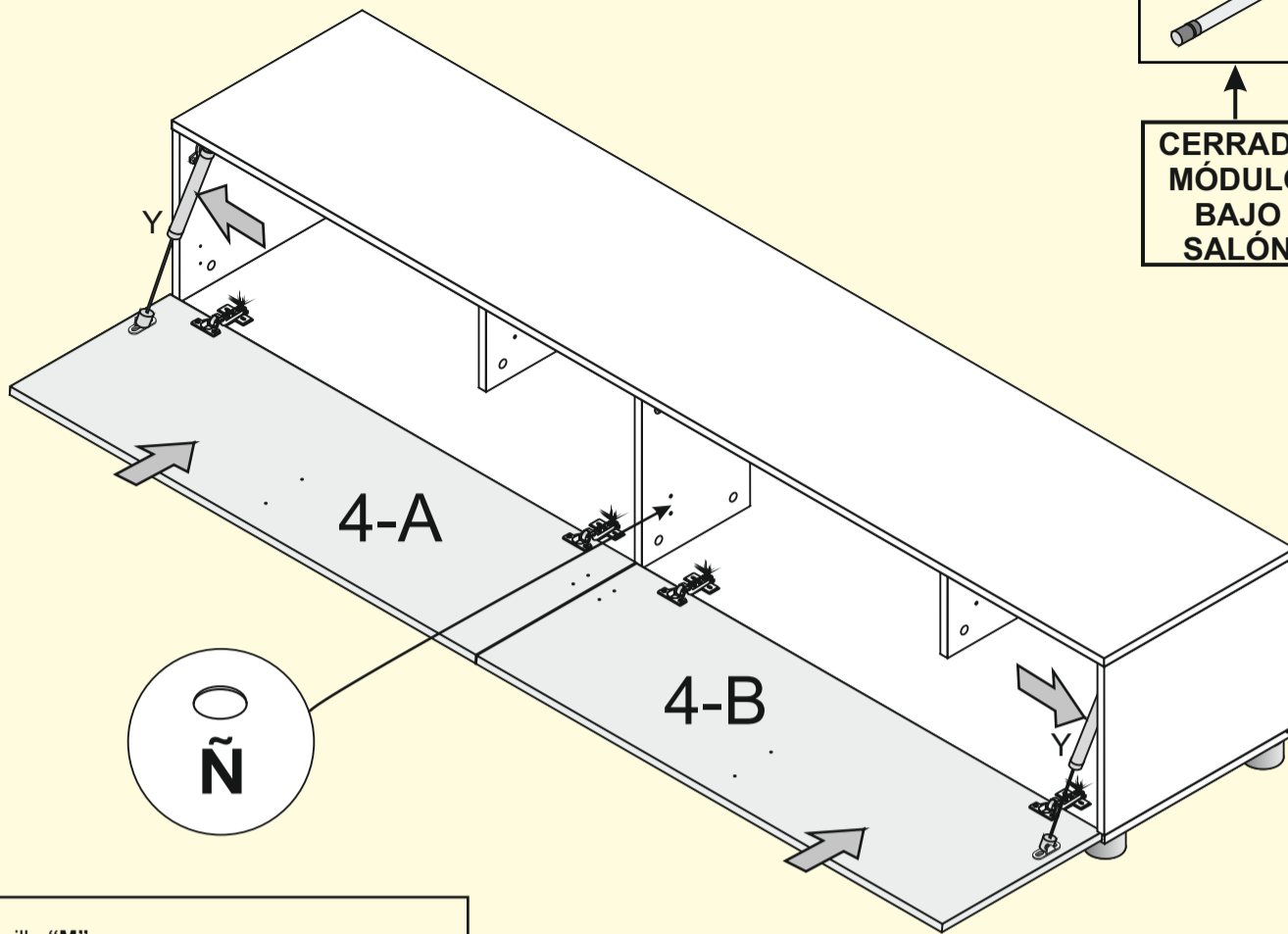
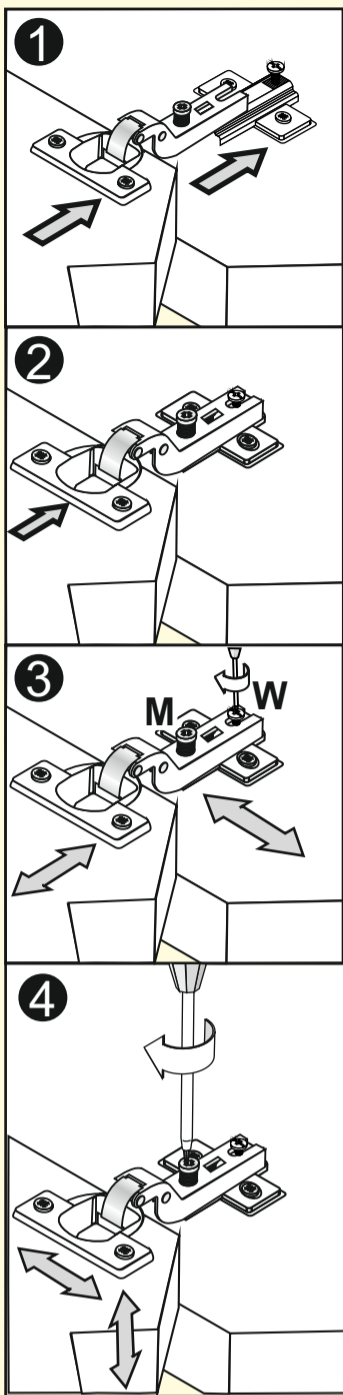

**ATENCIÓN ii**  
Antes de apretar el tornillo "M", hay que aflojar un poco el tornillo "W".

**ATTENTION ii**  
Before to tighten the screw "M" you have to slacken a little the screw "W"

**ATTENTION ii**  
Avant de presser le vis "M", il y a que relâcher un peu le vis "W"

**ATENÇÃO ii**  
Antes de apertar o parafuso "M", deve desapertar um pouco o parafuso "W".

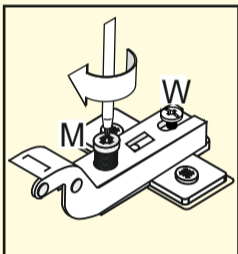

REGULACIÓN VERTICAL

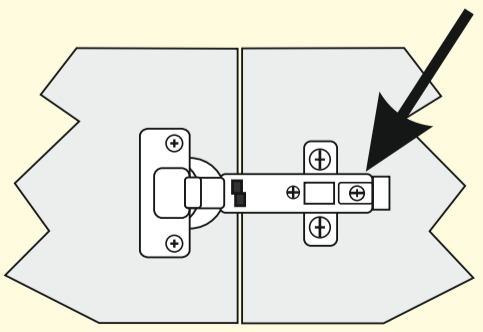
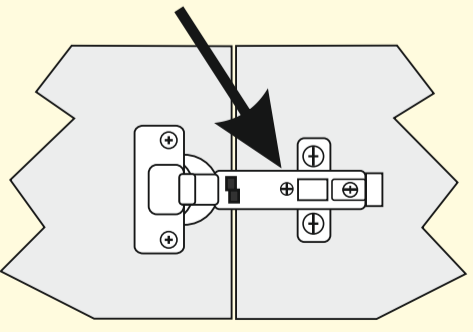
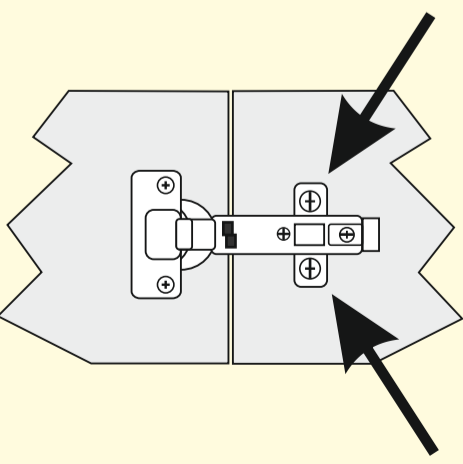
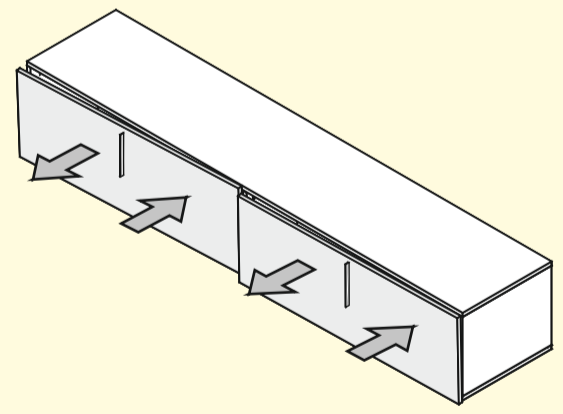
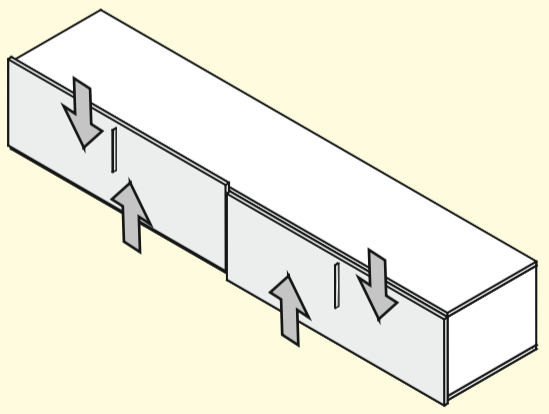
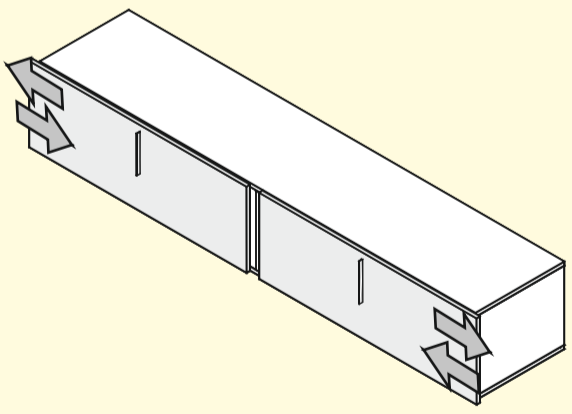

REGULACIÓN FRONTAL

REGULACIÓN LATERAL



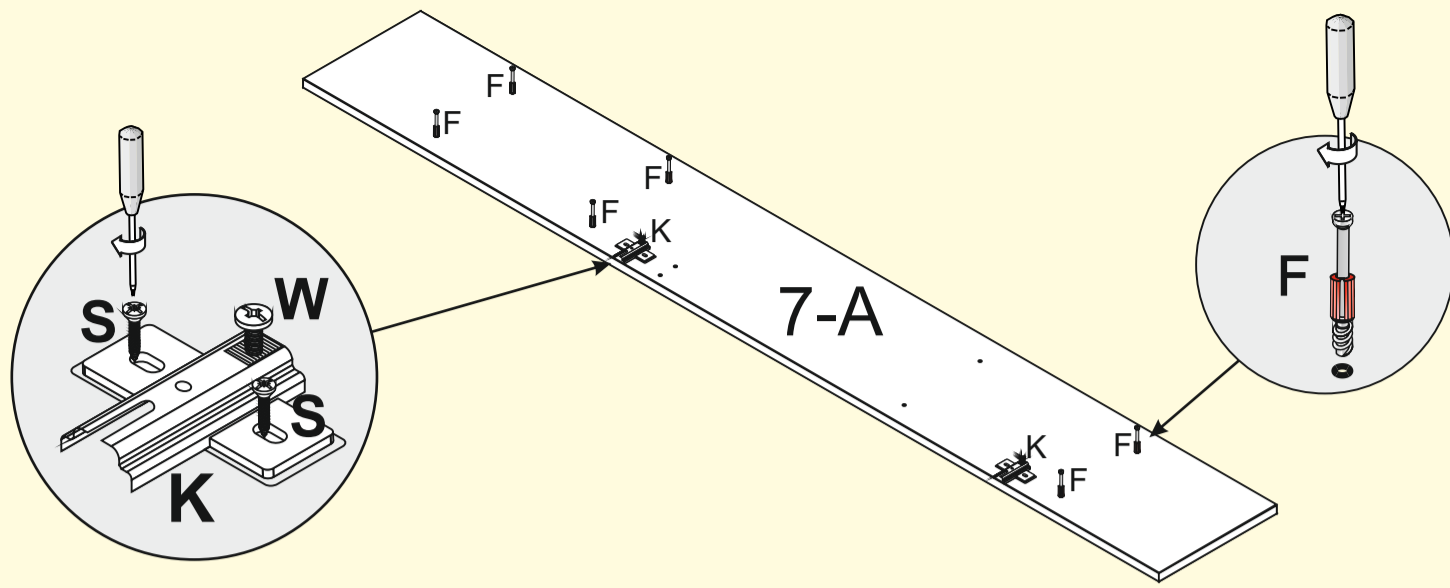

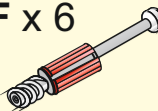
16

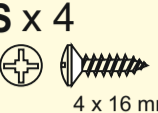

- F x 6 
- K x 2  W
- S x 4  4 x 16 mm

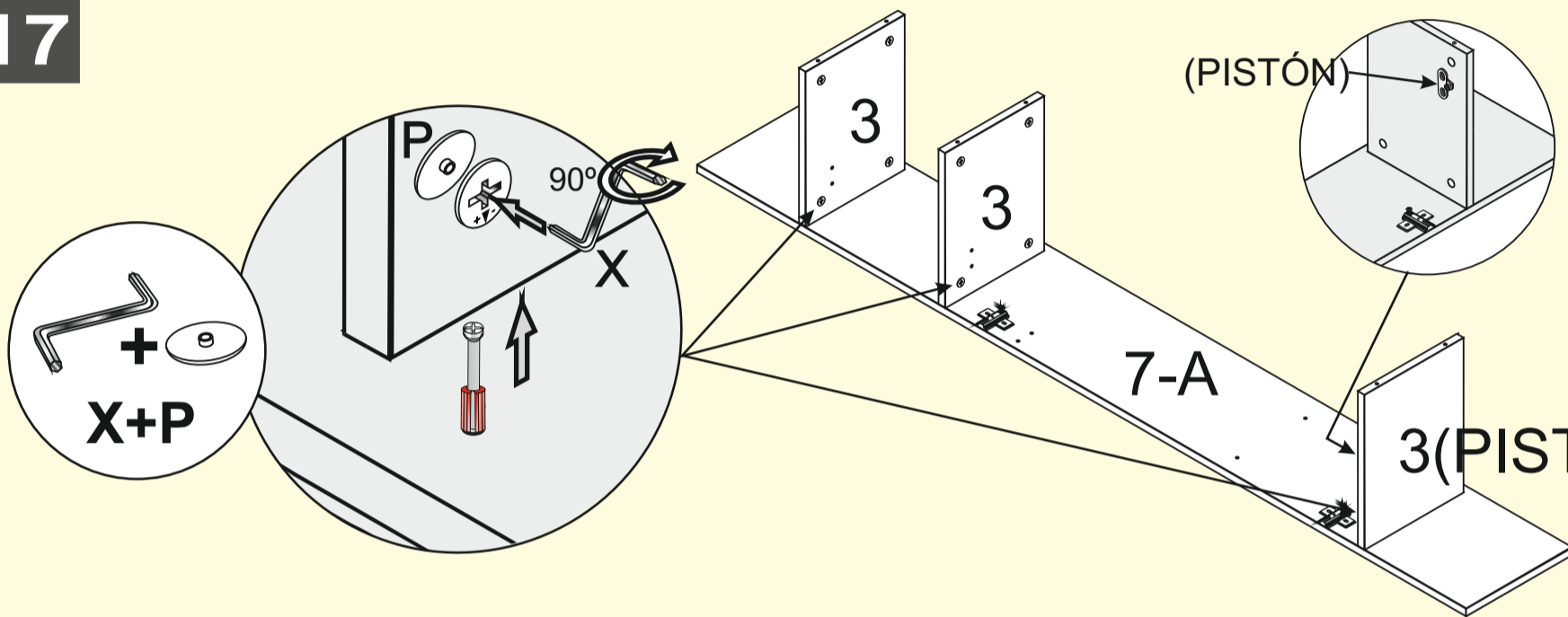
17

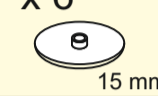

- P x 6  15 mm
- X x 1  N° 4

18

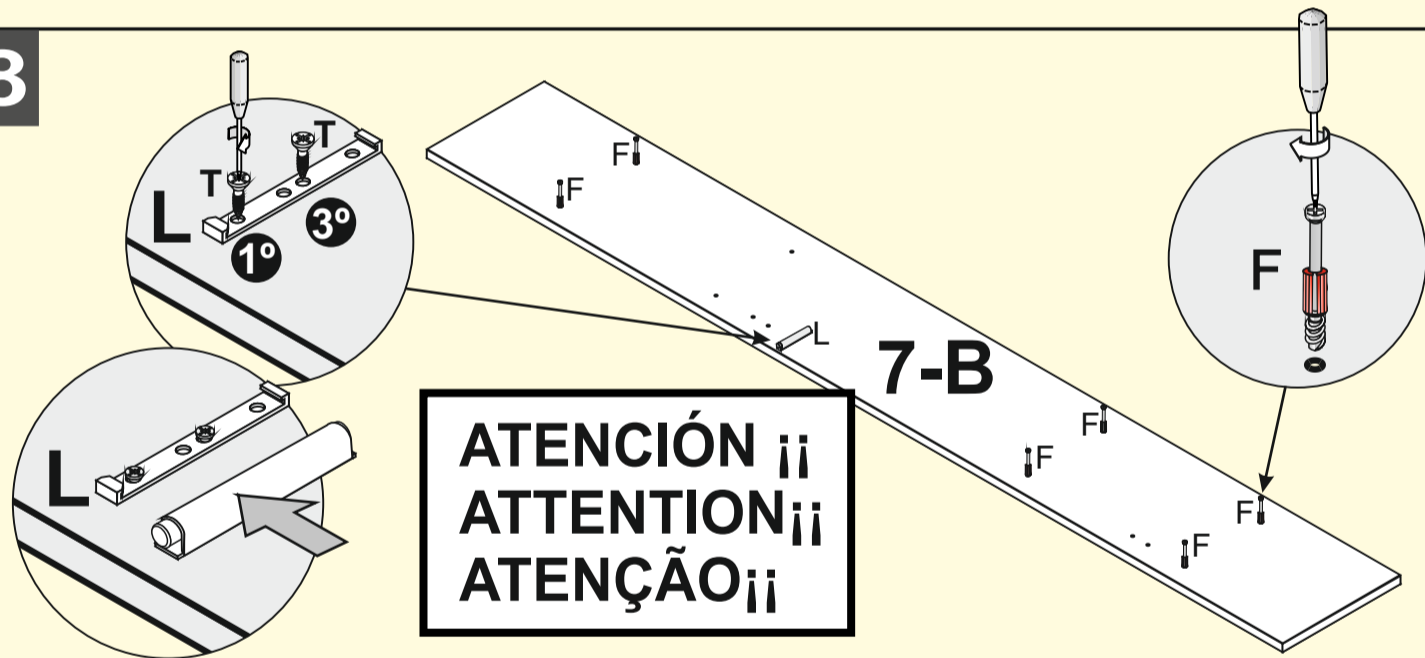

**EXPULSOR PUERTA REGULABLE**  
 GIRO HACIA LA IZQUIERDA  
 PARA REGULAR  
 LA APERTURA DE  
 LA PUERTA

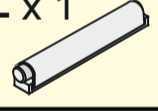
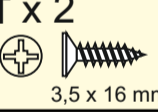
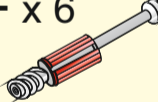

- L x 1 
- T x 2  3,5 x 16 mm
- F x 6 

19

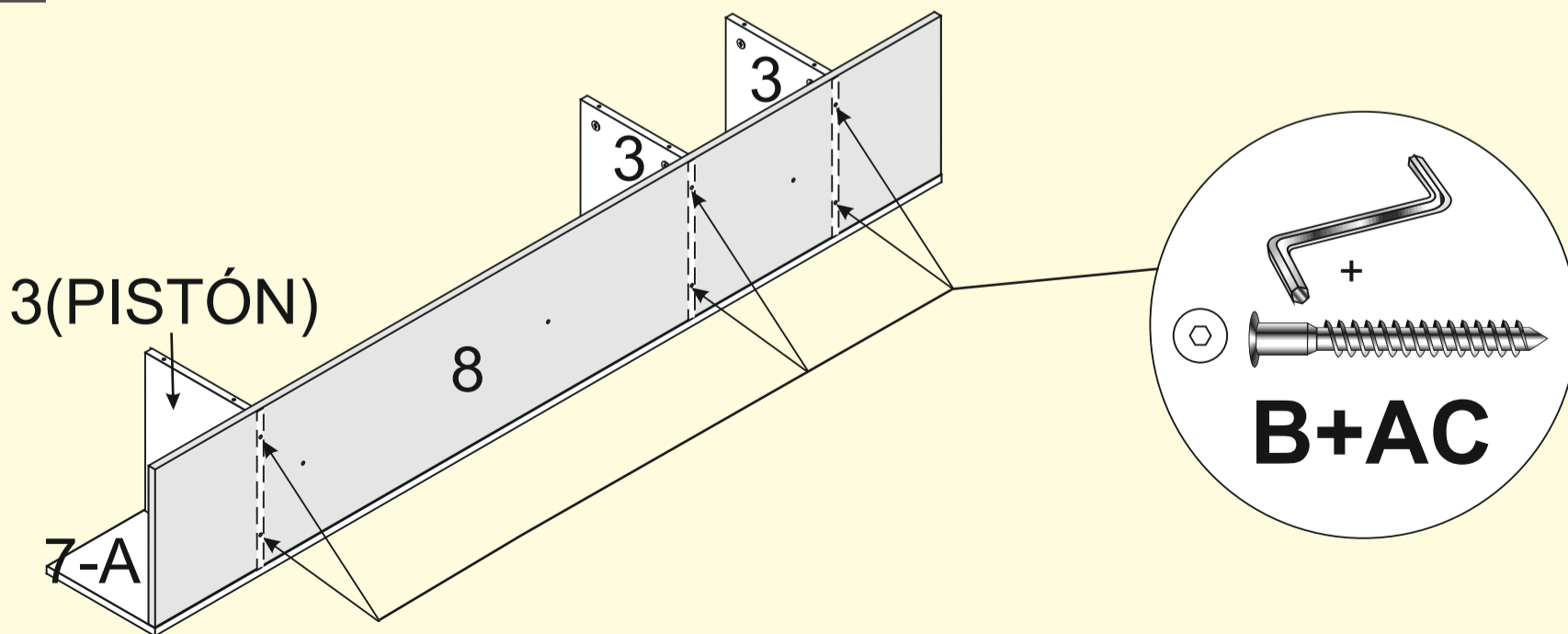

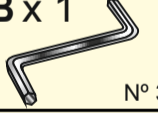
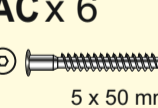
- B x 1  N° 3
- AC x 6  5 x 50 mm

20

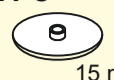
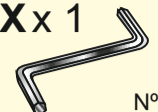
- P x 6  
  
 15 mm
- X x 1  
  
 N° 4

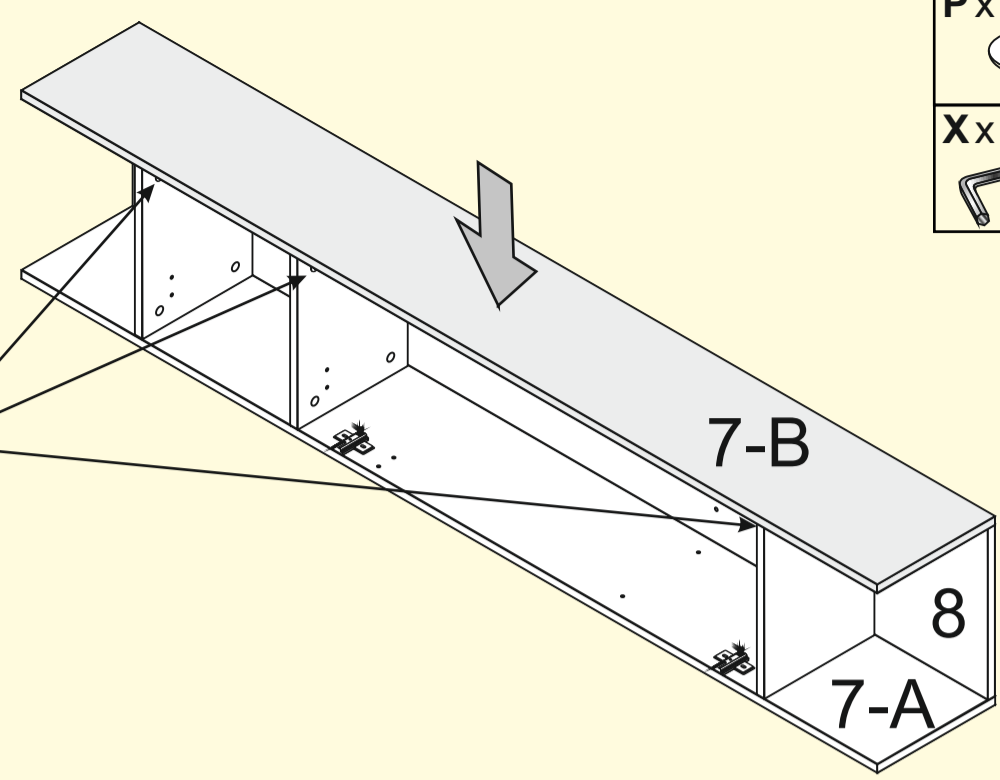
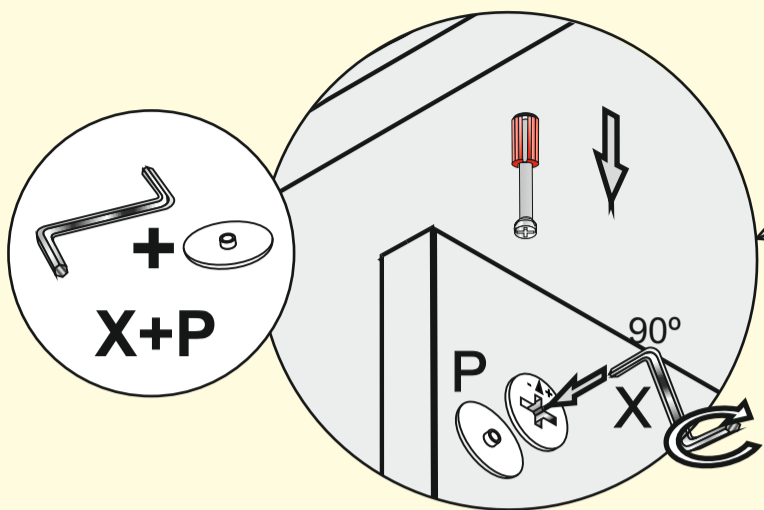

21

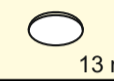
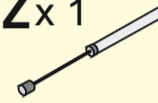
- Ñ x 14  
  
 13 mm
- Z x 1  

ABIERTO  
MÓDULO  
ALTO  
SALÓN

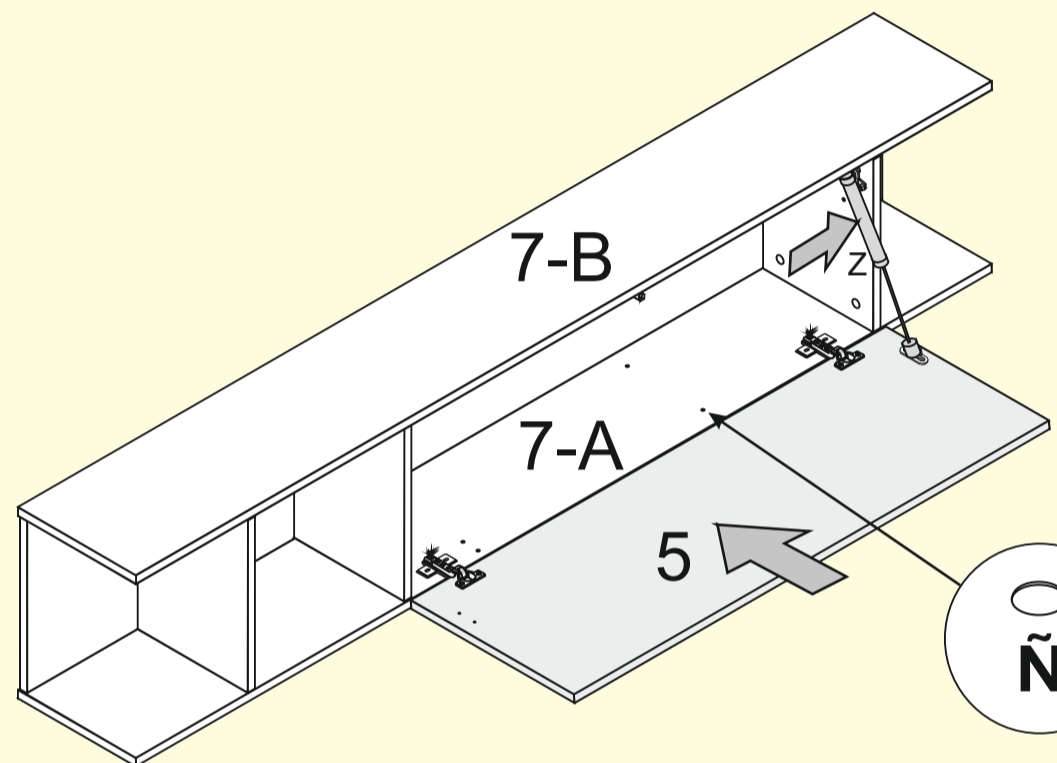
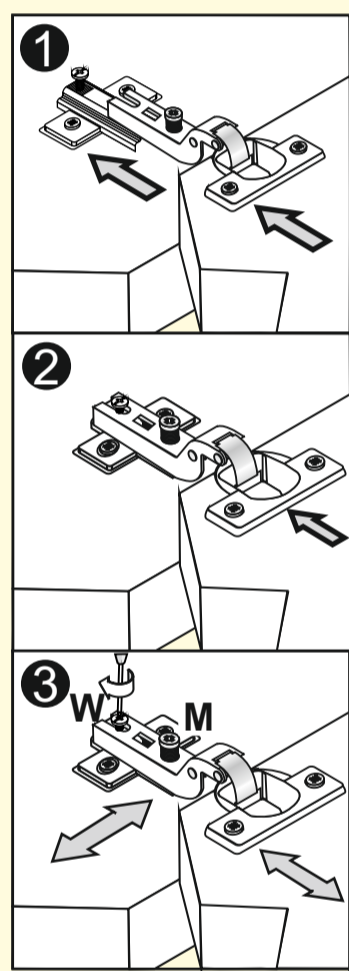

Ñ

**1**

**2**

**3**

**4**

**ATENCIÓN !!**  
 Antes de apretar el tornillo "M", hay que aflojar un poco el tornillo "W".

**ATTENTION !!**  
 Before to tighten the screw "M" you have to slacken a little the screw "W"

**ATTENTION !!**  
 Avant de presser le vis "M", il y a que relâcher un peu le vis "W"

**ATENÇÃO !!**  
 Antes de apertar o parafuso "M", deve desapertar um pouco o parafuso "W"

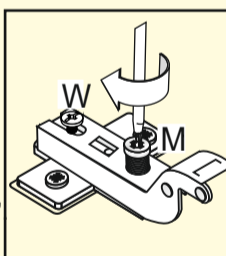

22

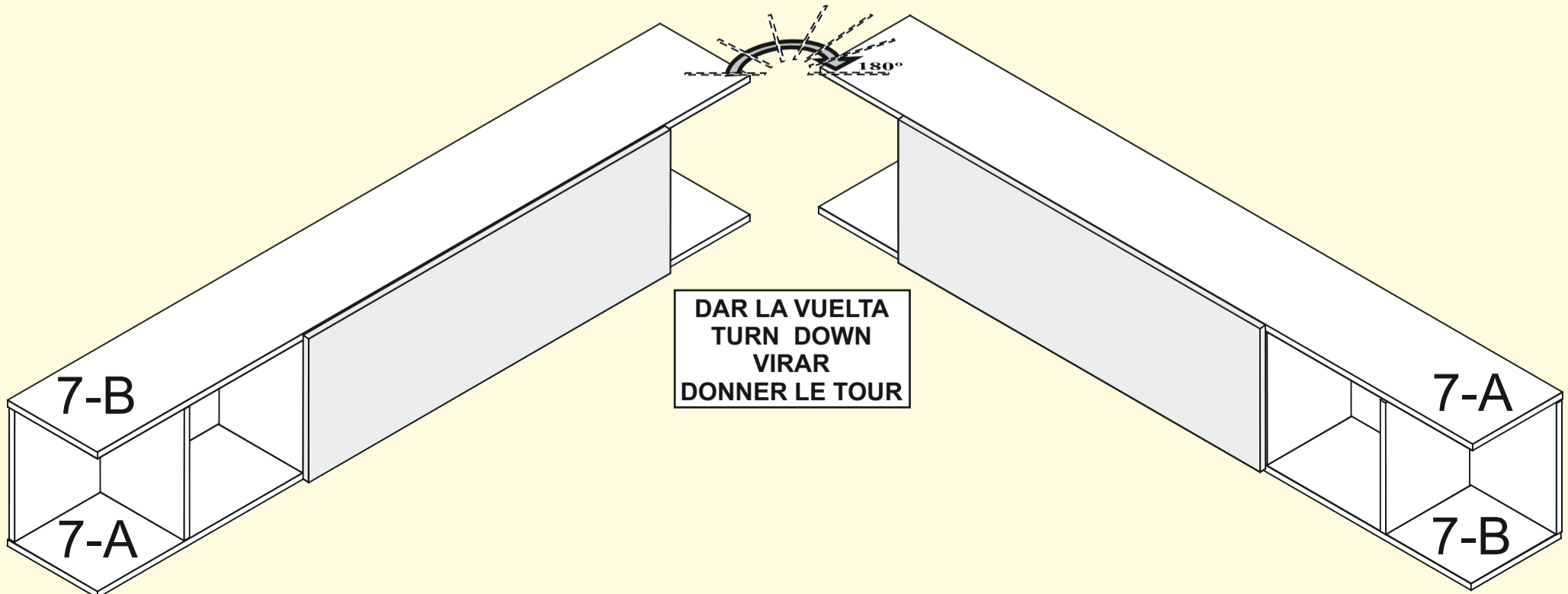

DAR LA VUELTA  
 TURN DOWN  
 VIRAR  
 DONNER LE TOUR

23

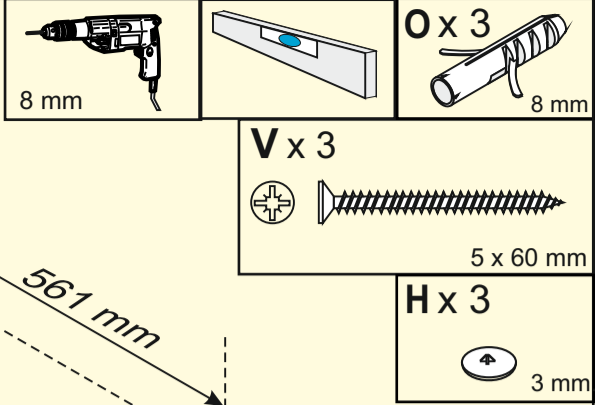

- 1)
- 2)
- 3)
- 4)
- 5)

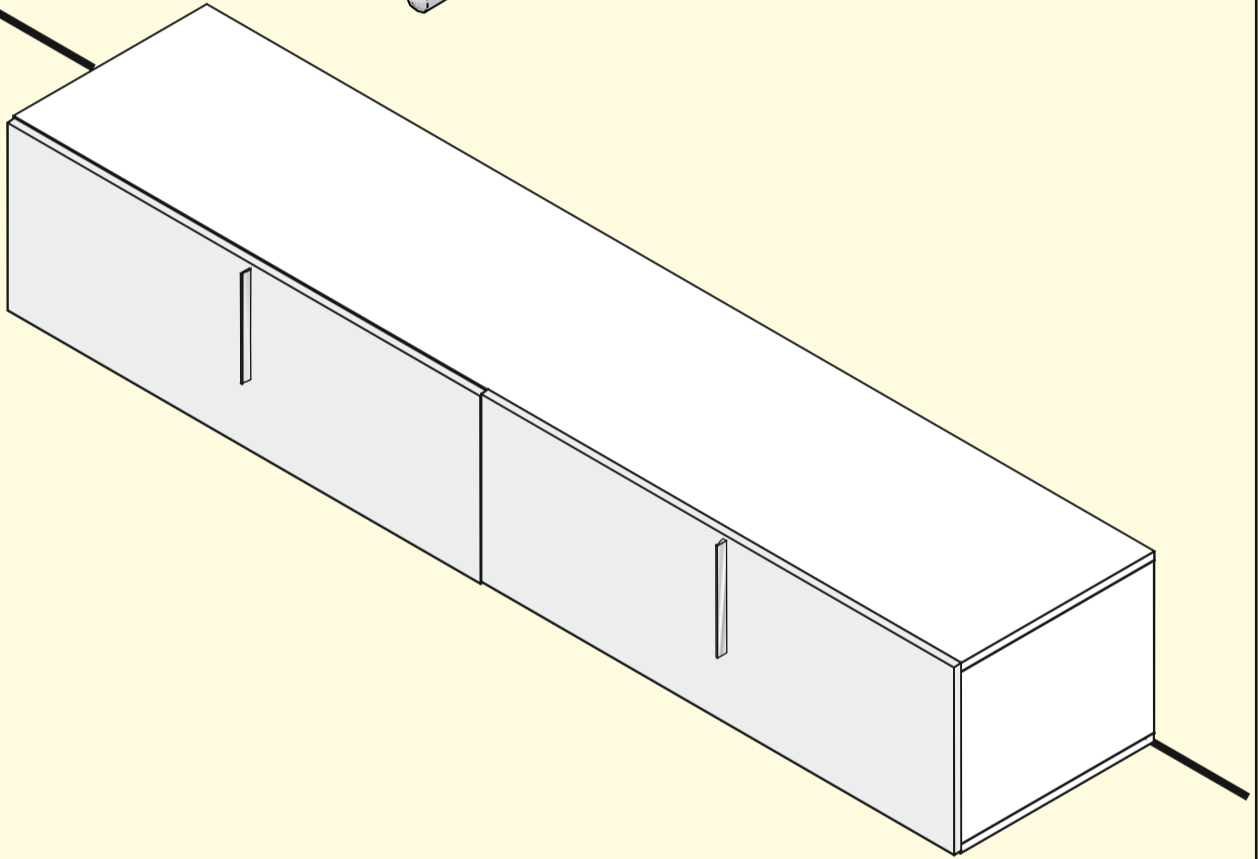
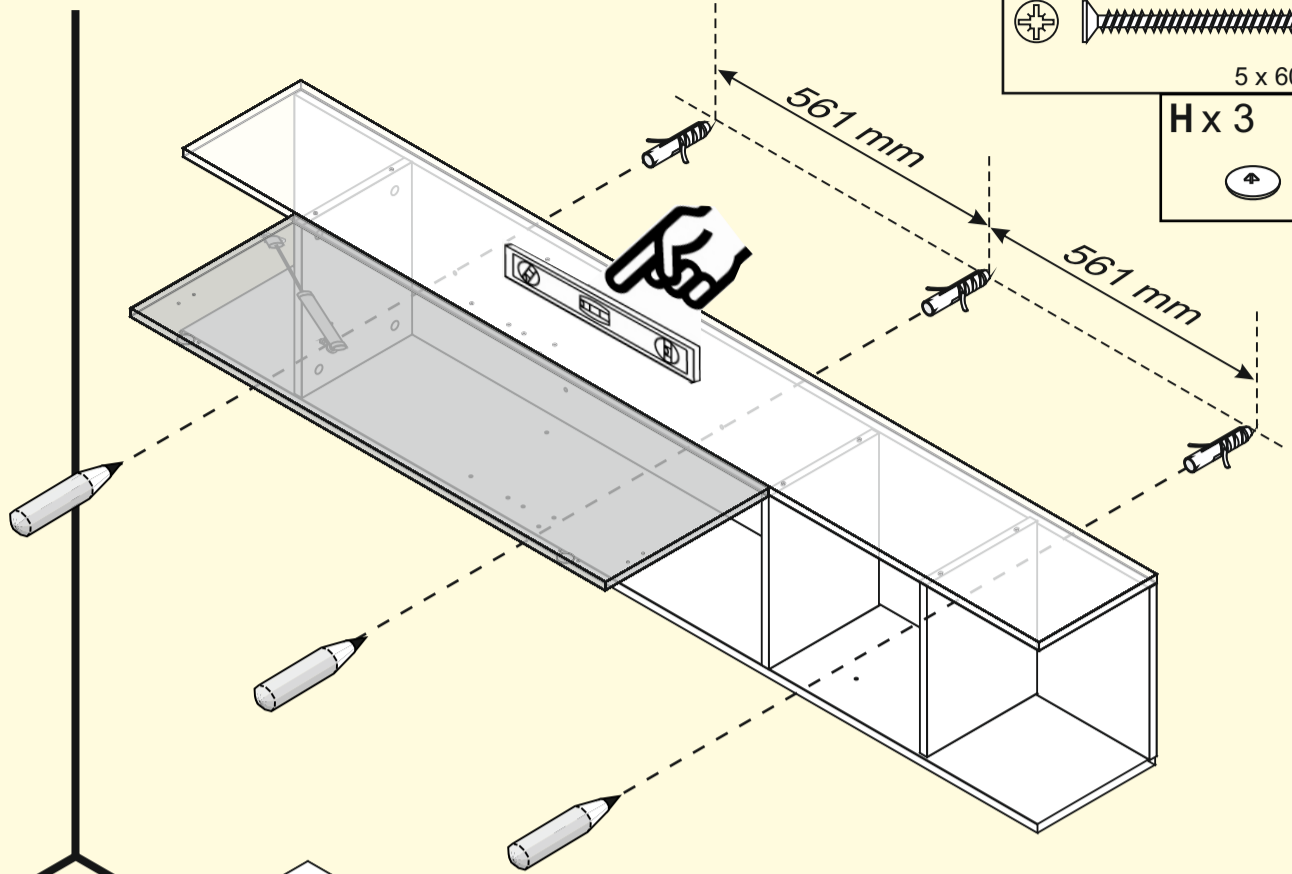

24

REGULACIÓN VERTICAL

REGULACIÓN FRONTAL

REGULACIÓN LATERAL

